

L A T E R A L H3500 T R A I N E R TOUCH

In a landmark study conducted by the University of Tampa Human Performance Lab, when compared to the leading elliptical trainer, Helix delivered dramatically increased muscle activation in literally 2/3 of the body, from “the core to the floor.” Here are the results:

Vastus Lateralus



Adductors



Gluteus Maximus



Gluteus Medius



Obliques



Rectus Abdominis



Spinal Erectors



As you can see, Helix training is **Radically Different AND Radically Effective.** It's no wonder users shape up faster with Helix!

The Most Effective Cardio Product Ever Built™

By training **more** muscle groups, and by creating **more** activation within those muscle groups, Helix burns more calories and delivers results **faster** than any other cardio product.



The patented 360° motion of Helix delivers a no-impact, super effective workout that engages multiple planes of human movement.



The state-of-the-art **TFT Touchscreen** is super intuitive, and the great graphics and feedback data will keep users motivated.

H3500 TOUCH

SPECS AT A GLANCE

- Resistance Type:** Generator Magnetic
- Resistance Method:** Electro-magnetic
- Resistance Levels:** 16
- Total Resistance (watts):** 400
- Flywheel Weight:** 26.4 lbs / 12kg
- Max User Weight:** 350 lbs / 159kg
- Unit Weight:** 225 lbs / 102kg
- Market:** Full Commercial
- Assembled Footprint:**
36" x 42" (92cm x 107cm)
- Packaging Dimensions:**
38" x 18" x 29"
(96.5cm x 45cm x 74cm)
- Power Requirements:** Self-generated
- Parts:** 3 years Commercial; 5 years Residential upon owner registration
- Labor:** 1 year



HLT3500

The **HLT3500 Standard** features the same great workout as the 3500 Touch, but with a classic dot matrix / LED console.

SPECS AT A GLANCE

- Resistance Type:** Generator Magnetic
- Resistance Method:** Electro-magnetic
- Resistance Levels:** 16
- Total Resistance (watts):** 400
- Programs:** Quick Start, Manual, Random, Interval, HR Control, Valley, Rolling Mountain, Olympian
- Feedback:** Time, Calories, RPM, Distance, HR, Level, Mets, Watts
- Flywheel Weight:** 26.4 lbs / 12kg
- Max User Weight:** 350 lbs / 159kg
- Unit Weight:** 225 lbs / 102kg
- Market:** Full Commercial
- Assembled Footprint:** 36" x 42" (92cm x 107cm)
- Packaging Dimensions:**
38" x 18" x 29" (96.5cm x 45cm x 74cm)
- Power Requirements:** Self-generated
- Parts:** 3 years Commercial; 5 years Residential upon owner registration
- Labor:** 1 year



L A T E R A L **HELIX** T R A I N E R RECUMBENT

Helix, the company that invented cardio lateral training, just revolutionized the recumbent workout.

Traditional "linear" recumbent bikes and steppers only work muscles in one plane—front to back. By contrast, the HR3500's patented Helix Motion Technology trains your body in multiple planes, a full 360°, thereby activating more muscles and burning more calories—in less time. Just read the science at Helixco.com/study and you'll see why it is the most effective cardio machine ever built. And, for those who prefer their workouts seated, there is no better workout option. It's time to take a seat, and take your fitness to a whole new level.

**Radically Different.
Radically Effective.
Radically Recumbent.**

✓
**The Most Effective
Cardio Product Ever Built™
is now available for
ALL fitness levels.**



360° Results: Unlike other cardio machines, Helix works the total lower body as it builds aerobic conditioning.

Glutes: The machine's intense focus on the Gluteus Maximus and Medius yields dramatic toning benefits.

Quads: Helix provides a zero-impact, yet powerful Quad workout.

Knees: Helix maintains and improves knee and hip functionality by safely targeting and strengthening the muscles that support these joints.

Stability/Fall Prevention: In a recent study, in just 4 months of moderate use, seniors were able to improve their lateral stability an average of 54%, thereby greatly reducing their risk of falling.

Imagine the lateral stability gains you could achieve by using a Helix recumbent on a regular basis!

Inner Thighs: Helix does what traditional cardio machines can't, creating up to 42% greater activation of the Adductor muscles.

Outer Thighs: Sculpts the hard-to-target outer thigh by creating up to 43% more Abductor muscle activation than a traditional cardio machine.

Helix®
World's First Lateral Trainer™

HR3500

Two options bring **Recumbent Lateral Training** to your gym...or your home.



HR3500

This commercial grade model boasts a smooth, gear-driven, maintenance-free system and an oversized, state-of-the-art TFT Touchscreen computer with full color screen. Super-intuitive graphics show real time feedback: time, calories, RPM, distance, pulse, activity level, mets and watts.

No electricity is required; the HR3500 features a self-powered generator, allowing for maximum flexibility of placement on the gym floor.

SPECS AT A GLANCE

- Unit Dimensions:** 74" x 36"
- Boxed Dimensions:** 42" x 42" x 43"
- Unit Weight:** 220 lbs
- Max User Weight:** 350 lbs
- Commercial Warranty:**
3 years parts, 1 year labor
- Residential Warranty:**
5 years parts, 1 year labor
- Power Requirements:**
Self-generating
- Resistance Method:** Electro-magnetic
- Resistance Levels:** 20
- Display:** TFT Touch full color
- Fit Programs:** 9



HR1000

The recumbent lateral trainer for home use, with a smooth, gear-driven, maintenance-free drive system. The HR1000 features an oversized Touchscreen LCD console with fit programs and real time feedback: time, calories, RPM, distance, pulse, activity level, mets and watts. Electricity is required.

The Helix HR1000 brings the power of recumbent lateral training into a residential setting.

SPECS AT A GLANCE

- Unit Dimensions:** 74" x 36"
- Boxed Dimensions:** 42" x 42" x 43"
- Unit Weight:** 210 lbs
- Max User Weight:** 300 lbs
- Warranty:** 2 years parts, 1 year labor
- Power Requirements:**
120vac 50/60hz
- Resistance Method:** ECB flywheel
- Resistance Levels:** 20
- Display:** Backlit LCD Touchscreen
- Fit Programs:** 11



Helix Company
572 Freeport Street, Unit A, Boston, MA 02122
Tel 888-HELIXCO Intl +1-617-710-8638
www.helixco.com



HELIX LATERAL TRAINER PRICE LIST 1/15/19

Description	Style Number	MSRP
Full Commercial Lateral Trainer	HLT3500 Touch	\$4499
Full Commercial Recumbent Lateral Trainer	HR3500 Touch	\$4499
Light Commercial Lateral Trainer	HLT2500	\$3499
Residential Lateral Trainer	H1000 Touch	\$2699
Residential Recumbent Lateral Trainer	HR1000 Touch	\$3199
TV Bracket for HLT3500	TV-Bracket	\$120



DEALER PRICING AS OF AUGUST 1st, 2018

CT LINE MACHINES		
Model	Part #	MSRP
Multi Pec Fly/ Rear Delt	CT-MFD	\$2,695
Multi Pec Fly/ Rear Delt with FULL Shrouds	CT-MFDS	\$3,045
Multi Lat / Arm	CT-MLA	\$2,595
Multi Lat / Arm with FULL Shrouds	CT-MLAS	\$2,945
Multi Press	CT-MPS	\$2,595
Multi Press with FULL Shrouds	CT-MPSS	\$2,945
Multi "Prone" Leg Extension / Leg Curl	CT-MEC	\$2,595
Multi "Prone" Leg Extension / Leg Curl with FULL Shrouds	CT-MECS	\$2,945
Multi " Seated" Leg Extension / Leg Curl	CT-MSEC	\$2,945
Multi " Seated" Leg Extension / Leg Curl with FULLShrouds	CT-MSECS	\$3,395
Multi Leg Press	CT-MLP	\$2,945
Multi Leg Press with FULL Shrouds	CT-MLPS	\$3,295
Incline Leg Press / Calf Raise (SLED)	CT-ILPC	\$3,495
Incline Leg Press / Calf Raise (SLED) with FULL Shrouds	CT-ILPCS	\$3,845
Multi Bicep / Tricep	CT-MBT	\$2,695
Multi Bicep / Tricep with REAR Shrouds	CT-MBTS	\$2,895
Multi Inner / Outer Thigh	CT-MIO	\$2,795
Multi Inner / Outer Thigh with REAR Shrouds	CT-MIOS	\$3,045
Multi AB / Back	CT-MAB	\$2,595
Multi AB / Back with REAR Shrouds	CT-MABS	\$2,795
Multi Hip	CT-MHP	\$3,045
Multi Hip with REAR Shrouds	CT-MHPS	\$3,295
Chin/Dip Assist	CT-CDA	\$3,595
Chin/Dip Assist with FULL Shrouds	CT-CDAS	\$3,895
Chin/Dip Assist Rope Attachment for 8FT Ceiling	CT-ROPE8	\$245

INFLIGHT FITNESS

8321 Standustrial Street, Stanton, CA 90680
 (714) 821-4177 phone (714) 821-4181 fax
 email sales@inflightfitness.com



DEALER PRICING AS OF AUGUST 1st, 2018

FUNCTIONAL TRAINING		
Model	Part #	MSRP
Adjustable Cable Column	FT-CLM	\$2,595
Adjustable Cable Column with FULL Shrouds	FT-CLMS	\$2,945
Cable Cross- Over w/84" Crossbeam	FT-CCO	\$4,495
Cable Cross- Over w/84" Crossbeam with REAR Shrouds	FT-CCOS	\$4,795
Cable Cross-Over w/ 54" Crossbeam	FT-CCOC	\$4,495
Cable Cross-Over w/54" Crossbeam with REAR Shrouds	FT-CCOCS	\$4,795
Cable Cross-Over w/Monkey Bar Crossbeam	FT-CCOMF	\$4,845
Cable Cross-Over w/Monkey Bar Crossbeam with REAR Shrouds	FT-CCOMFS	\$4,995
2-Stack Functional Trainer	FT1000	\$3,245
2-Stack Functional Trainer with REAR Shrouds	FT1000S	\$3,595
FT1000 5 Piece Accessory Kit	FT1000AK	\$445
4:1 Weight Ratio Kit	FT100041	\$295
CT LINE AND FUNCTIONAL TRAINING OPTIONS		
Model	Part #	MSRP
Heavy Stack - 50 LBS (add heavy stacks to all 200lb stack CT Line Units and 150lb Stack FT1000 up to 300lbs) **No Additional weight can be added to the CT-MHP and CT-MBT. Only one heavy Stack can be added to the CT-MIO**	HVY	\$150
Custom Logo Wear Guards (Not Available on units without backrests). Quantity of 1-8 Wear Guards, 8 Unit Maximum per \$250	LOGO	\$495
Custom Colored Upholstery - Price Per Piece or Station. Lead-time approximately 2-3 weeks. Please call for colors and availability.	UPH	\$175

INFLIGHT FITNESS
 8321 Standustrial Street, Stanton, CA 90680
 (714) 821-4177 phone (714) 821-4181 fax
 email sales@inflightfitness.com



DEALER PRICING AS OF AUGUST 1st, 2018

MULTI GYMS		
Model	Part #	MSRP
Vanguard 2 Stack, 3 Station	3070	\$4,195
Vanguard 2 Stack, 3 Station with FULL Shrouds	3070S	\$4,995
Vanguard Leg Press Option - Shared Stack	3075	\$1,195
Vanguard Cable Column Option - Shared Stack	3080	\$1,195
Vanguard 3rd Stack Leg Press Option (No Shrouds Available)	6075V	\$1,895
Vanguard 3rd Stack Cable Column Option	3085	\$1,995
Vanguard 3rd Stack Cable Column Option with FULL Shrouds	3085S	\$2,295
Vanguard 3rd Stack Chin/Dip Assist Option	3087	\$3,095
Vanguard 3rd Stack Chin/Dip Assist Option with FULL Shrouds	3087S	\$3,395
Vanguard 4 Stack w/Cable Crossover with 84" Crossbeam	3090	\$8,395
Vanguard 4 Stack w/Cable Crossover with 84" Crossbeam with Shrouds	3090S	\$9,595
Vanguard 4 Stack w/Cable Crossover 54" Crossbeam	3090C	\$8,395
Vanguard 4 Stack w/Cable Crossover with 54" Crossbeam with Shrouds	3090CS	\$9,595
Vanguard 4 Stack w/Cable Crossover "Monkey Bar" Crossbeam	3090MF	\$8,795
Vanguard 4 Stack w/Cable Crossover "Monkey Bar" Crossbeam with Shrouds	3090MFS	\$9,995
Vanguard 6 Stack w/CCO with 84" Crossbeam	3099	\$12,590
Vanguard 6 Stack w/CCO with 84" Crossbeam with Shrouds	3099S	\$14,590
Vanguard 6 Stack w/CCO Compact 54" Crossbeam	3099C	\$12,590
Vanguard 6 Stack w/CCO Compact 54" Crossbeam with Shrouds	3099CS	\$14,590
Vanguard 6 Stack w/CCO "Monkey Bar" Crossbeam	3099MF	\$12,990
Vanguard 6 Stack w/CCCO "Monkey Bar" Crossbeam with Shrouds	3099MFS	\$14,990

INFLIGHT FITNESS

8321 Standustrial Street, Stanton, CA 90680
 (714) 821-4177 phone (714) 821-4181 fax
 email sales@inflightfitness.com



DEALER PRICING AS OF AUGUST 1st, 2018

MULTI GYMS Continued		
Model	Part #	MSRP
Liberator 3 Stack, 4 Station	6070	\$5,795
Liberator 3 Stack, 4 Station with FULL Shrouds	6070S	\$6,595
Liberator 4th Stack Leg Press Option (No Shrouds Available)	6075	\$1,895
Liberator 4th Stack Cable Column Option	6080	\$1,995
Liberator 4th Stack Cable Column Option with FULL Shrouds	6080S	\$2,295
Liberator 4th Stack with Chin/Dip Assist Option	6087	\$3,095
Liberator 4th Stack with Chin/Dip Assist Option with Shrouds	6087S	\$3,395
Liberator 5 Stack w/Cable Crossover 84" Crossbeam	6090	\$9,995
Liberator 5 Stack w/Cable Crossover 84" Crossbeam with Shrouds	6090S	\$11,195
Liberator 5 Stack w/Cable Crossover 54" Crossbeam	6090C	\$9,995
Liberator 5 Stack w/Cable Crossover 54" Crossbeam with Shrouds	6090CS	\$11,195
Liberator 5 Stack w/Cable Crossover "Monkey Bar" Cross	6090MF	\$10,395
Liberator 5 Stack w/Cable Crossover "Monkey Bar" Crossbeam with Shrouds	6090MFS	\$11,595
Liberator 8 Stack w/Cable Crossover 84" Crossbeam	6099	\$15,790
Liberator 8 Stack w/Cable Crossover 84" Crossbeam with Shrouds	6099S	\$17,790
Liberator 8 Stack w/Cable Crossover 54" Crossbeam	6099C	\$15,790
Liberator 8 Stack w/Cable Crossover 54" Crossbeam with Shrouds	6099CS	\$17,790
Liberator 8 Stack w/Cable Crossover "Monkey Bar" Cross	6099MF	\$16,190
Liberator 8 Stack w/Cable Crossover "Monkey Bar" Crossbeam with Shrouds	6099MFS	\$18,190
MULTI GYM OPTIONS		
Heavy Stack - 50 LBS (50lbs to weight stacks up to 300lbs)	HVY	\$150
Custom Logo Wear Guards (Not Available on Stations without backrests). Quantity of 1-8 Wear Guards, 8 Unit	LOGO	\$495

INFLIGHT FITNESS

8321 Standustrial Street, Stanton, CA 90680
 (714) 821-4177 phone (714) 821-4181 fax
 email sales@inflightfitness.com



DEALER PRICING AS OF AUGUST 1st, 2018

Custom Colored Upholstery - Price Per Station. Lead-time approximately 2-3 weeks. Please call for colors and availability.	UPH	\$175
--	-----	-------

INFLIGHT FITNESS

8321 Standustrial Street, Stanton, CA 90680
(714) 821-4177 phone (714) 821-4181 fax
email sales@inflightfitness.com



DEALER PRICING AS OF AUGUST 1st, 2018

FREE WEIGHTS		
Model	Part #	MSRP
Intimidator 8 Foot Power Rack - 8 Foot Power Rack with Olympic Plate Holders, Chain and Band Storage	5006	\$2,695
Intimidator 8 Foot Power Rack - BASIC 8 Foot Power Rack with Upper Band Pegs - No Plate Storage	5006B	\$1,995
Deluxe Safety Spotter Arms - Upgrade Deluxe Safety Spotters Arms with Scratch Resistant Stainless Steel Bar Rests	5006-SA	\$425
Monkey Bar Chin Up Bar- Deluxe Monkey Bar Chin-Up Bar with Multi-Postional Hand Grips	5006-CU	\$225
Optional Lower Band Pegs - 2 Band Pegs per Box. Lower Band Pegs are Adjustable. 5 Pairs can be added to each rack. Upper Band Pegs are welded and come standard.	5006-BP	\$70
Optional 2nd Set of "J" Hooks	5006-BH	\$275
Optional Weight Horn Set	5006-WH	\$95
Olympic Bench with Weight Horns	5000	\$895
Adjustable Decline AB Bench	5001	\$695
Flat Bench	5002	\$295
Counter Balanced Smith Machine	5003	\$2,995
Flat-Incline-Decline (FID) Bench	5005	\$695
Utility Bench	5010	\$445
Preacher Curl Bench	5011	\$795
Preacher Curl Bench Weight Horns (1 Pair)	5011WH	\$75
Hyper-Back Extension	5070	\$595
VKR-DIP	VKR	\$695
FREE WEIGHT OPTIONS		
Model	Part #	MSRP
Custom Logo Wear Guards (Not Available on units without backrests). Quantity of 1-8 Wear Guards, 8 Unit Maximum per \$250	LOGO	\$495
Custom Colored Upholstery - Price Per Piece or Station. Lead-time approximately 2-3 weeks. Please all for colors and availabilty.	UPH	\$175



DEALER PRICING AS OF AUGUST 1st, 2018

DUMBBELL RACKS AND DUMBBELL SETS

Model	Part #	MSRP
65" Deluxe 2-Tier Hex DB Rack (2 x 4 Oval Tubing)	5004	\$795
65" Deluxe 2-Tier Hex DB Rack (2 x 4 Oval Tubing) with a 10 Pair (5- 50lb) Rubber Hex Dumbbell Set	5004-550HXP	\$1,995
69" 2-Tier DB Rack - Tray Style (69" Trays)	5007-2	\$695
69" 2-Tier DB Rack - Tray Style (69" Trays) with a 10 Pair (5-50lb) Rubber Hex Dumbbell Set	5007-2-550HXP	\$1,895
69" 3-Tier DB Rack - Tray Style (69" Trays)	5007-3	\$995
69" 3-Tier DB Rack - Tray Style (69" Trays) with a 15 Pair (5-75lb) Rubber Hex Dumbbell Set	5007-3-1200HXP	\$3,595
8- Pair Vertical DB Rack	5008	\$395
8- Pair Vertical DB Rack with a 8 Pair (5-40lb) Rubber Hex Dumbbell Set	5008-360HXP	\$1,195
54" 3-Tier DB Rack - Tray Style (54" Trays)	5009	\$945
54" 3-Tier DB Rack - Tray Style (54" Trays) with a 10 Pair (5-50lb) Rubber Hex Dumbbell Set	5009-550HXP	\$2,295
54" 3-Tier DB Rack - Tray Style (54" Trays) with a 13 Pair (5-50lb and 3,8,12) Rubber Hex Dumbbell Set	5009-596HXP	\$2,425
108" MEGA 3-Tier DB Rack - (Two 54" 3-Tray Racks) with a 20 Pair (5-100lb) Rubber Hex Dumbbell Set	5009-2100HXP	\$6,495

INFLIGHT FITNESS

8321 Standustrial Street, Stanton, CA 90680

(714) 821-4177 phone (714) 821-4181 fax

email sales@inflightfitness.com



LIBERATOR

MULTI-STACK FITNESS SYSTEM



The Liberator by Inflight Fitness is the most compact, versatile, and durable commercial strength training system on the market today.

Modern styling and rugged dependability are combined in a compact package that is destined to meet your budget and exceed any workout enthusiast's expectations.

The Liberator Strength Training system allows three users to workout simultaneously and four users when you add the optional fourth weight stack. Simplicity and reliability in design are hallmarks of the Liberator Strength Training System, with minimal adjustments to manage and the heaviest duty commercial components for reliability.

The Liberator Strength Training System IS the strength training system you have been searching for!!!



Shown with optional shrouds

THE Ultimate three or four weight stack Strength Training System for your gym or fitness center!



Optional 4th Stack Leg Press



Optional 4th Stack Cable Column



Standard Liberator Configuration



Commercial rated 1" shafts and pillow block bearings assure precise movement while providing ultimate durability.

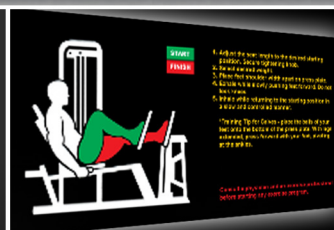

Each exercise station features easy to understand instructional placards to demonstrate machine set-up, proper form, and targeted muscle groups.



Premium upholstered padding is full commercial, 40-50 durometer HR foam with sewn vinyl covers for maximum strength and a tailored look. Contoured seat and back pads provide lumbar support and maximum comfort.



The open yoke Lat Pulldown has wide-open head clearance for safety. Also, the Shoulder Press allows for presses to be performed seated upright, facing in or out, for greater joint comfort.



Our cables are twice as strong as most competitors' cables. We use Loos USA 4000lb rated military-spec cables with stainless steel swaged ball ends for maximum life expectancy and user safety. The cables are routed over extra large 4 1/2" and 6" pulleys.



All Hand Grips are made of non-absorbent UV resistant, closed cell foam and are finished with machined aluminum grip caps to prevent wear while looking great. Hand Grips are positioned to keep joints in a neutral position, reducing joint stress and maximizing a safe workout experience.



Each station boasts a 200lb. tiered weight stack. Additional weight can be ordered in 50lb. increments up to 300lb per station! Steel weight stack selector pins are attached by a coiled lanyard to help prevent loss.



The Liberator Strength Training System allows the user to position the seats for their height and comfort with our easy to use ratchet adjustment system.

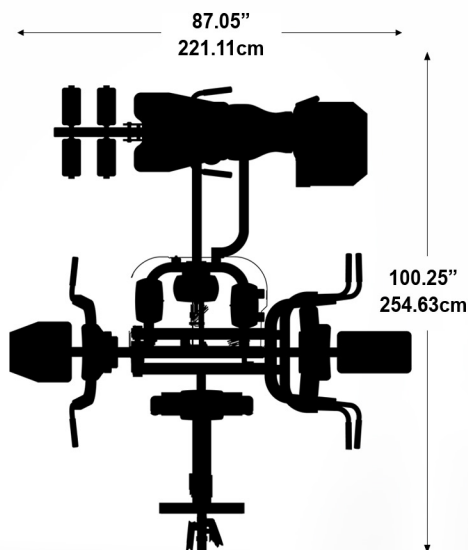

With Optional 4th Stack Cable Column

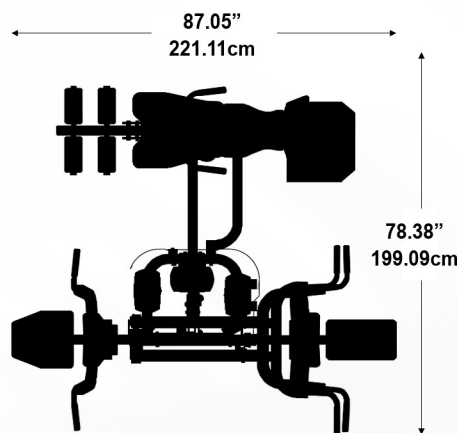

Standard 3 Stack Configuration

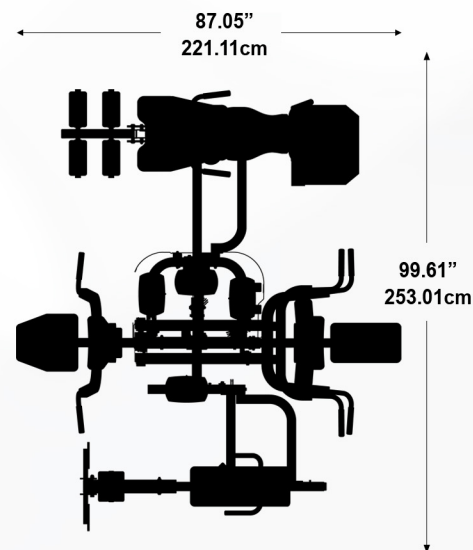

With Optional 4th Stack Leg Press

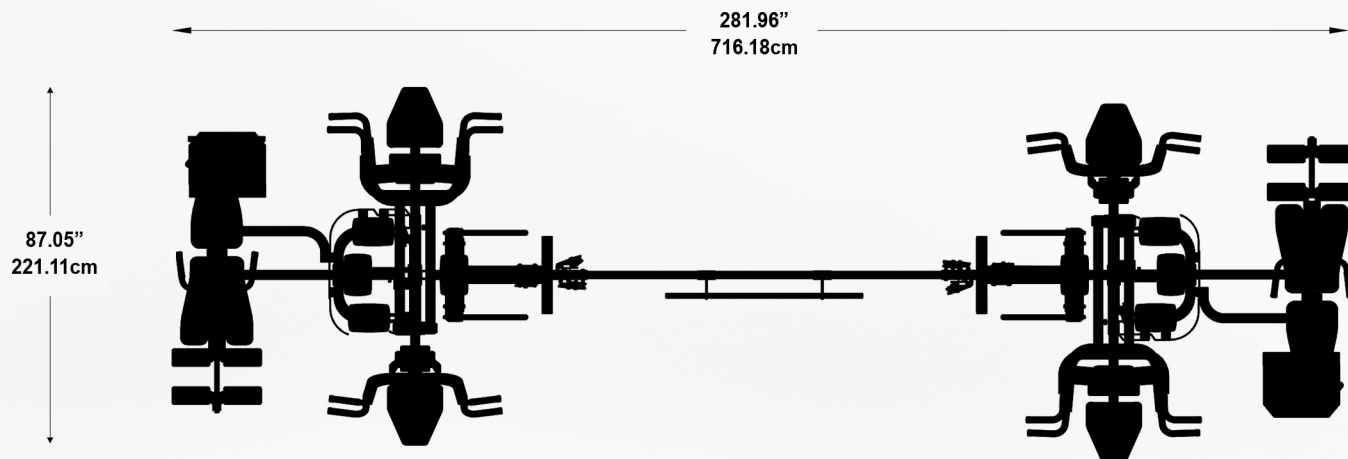

8 Stack Multi-Gym Configuration

EXERCISE STATIONS

- STATION 1:** Lat Pull, Shoulder Press
- STATION 2:** Seated Leg Extension, Lying Leg Curl, Bicep Curl, Low Row
- STATION 3:** Chest Press, Ab Crunch, Overhead Triceps
- STATION 4:** Leg Press OR Cable Column
- 8 STACK:** Standard Stations 1-3 Plus Cable Column (x2)

All Inflight Fitness Machines have a lifetime warranty on the frame and welds and one year on cables, pulleys and moving parts. Additional terms and conditions apply. See warranty for details. Inflight Fitness reserves the right to make design changes at any time.



8321 STANDUSTRIAL STREET - STANTON, CA 90680 - TEL. 714 821 4177 - FAX. 714 821 4181
www.inflightfitness.com

See more at www.inflightfitness.com or on Facebook at Inflight Fitness Products



platinum
series

11 1241 124 01.11 009 1241 717
1241 01 717 1241 1241 888 888



1

Welcome to Inflight Fitness, a U.S. designer and manufacturer of commercial strength training equipment.

In-Flight Products was founded in 1991 as an aircraft parts manufacturer and entered the fitness industry by producing OEM parts and complete machines for a major fitness company. In 2001, Inflight Fitness was launched as its own brand with the acquisition of the Pacific Fitness SE line of commercial strength equipment.

Today, Inflight Fitness combines the quality demanded by the aircraft industry with over twelve years of experience manufacturing commercial fitness equipment to bring you the exceptional value of the Platinum Series.

The Inflight Fitness Platinum Series is engineered to be durable and easy to use while providing great workouts. You will find the Platinum Series is well designed to fit your exercise needs, to fit your most limited spaces and also to fit your budget.

Inflight Fitness compact multi-function strength trainers are in use in gyms, hotels, studios, schools and government facilities across the United States and around the world in countries such as Dubai, Egypt, Ireland, Singapore, Malaysia, Indonesia, China, India, Mexico, Canada, and the Philippines.



INFLIGHT FITNESS

mla
multi
lat/arm

3



versatile

mps
multi
press





mfd
multi
fly/delt



mbt
multi
bicep/tricep



mab

multi
ab/back

mhp

multi
hip/glute



5

compact



mec
multi leg
extension/curl



mio
multi
inner/outer

7



mip
multi
leg pres



msec
seated
leg extension/leg curl

ilpc

incline
leg press/calf raise



smooth



functional

clm
cable column

cco
cable
cross over



ft 1000

functional trainer



shown with optional accessories

step



standard
configuration

power rack

weight plates and bar
not included



optional
configuration



12

smith
machine

counterbalanced

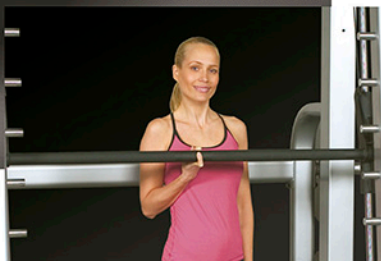

fid
bench

hex
dumbbell
rack

13



rugged

olympic
bench

flat
bench



attractive



hyper
back extension



ab
bench



vkr
dip

features

in all platinum
series machines



Extensive use of 1" shafts and ABEC rated ball bearings at exercise pivots assures smooth movement.



All frames feature 2" x 4" attractive flat oval tubing electrostatically powder coated a rich platinum color that complements modern cardio equipment.



We use Loos USA 4000# rated cable with corrosion resistant stainless steel swaged ball ends for safety over 4 1/2" ball bearing pulleys for smooth quiet operation. Cable tension is easily maintained with the cam washer above the weight stack.



All machines come with easy to understand exercise placards.



Non-absorbent UV resistant closed cell foam grips are finished with machined aluminum grip caps to prevent wear while looking great.



The optional shrouds are Q40 thick steel powder coated and then clear coated for a lustrous mar resistant finish.



Seat and back pads are 40-45 durometer HR foam contoured for comfort and lumbar support with sewn vinyl covers for a tailored look.



Our cast steel weight plates are warranted lifetime against breakage. They move on 1" rubber capped floating guide rods with self-aligning plastic bushings and rubber weight stack cushions at the base to reduce noise.

p/n	description	dimensions (LxWxH)	stack	features
selectorized machines				
CT-MLA	Multi-Lat/Arm	US 78" x 47" x 82"	200 lbs	The most versatile machine of its type
		Int'l 198 cm x 119 cm x 208 cm	90 kg	Adjustable thigh pad/presser curl pad
CT-MPS	Multi-Press	US 68" x 42" x 81"	200 lbs	Back pad and press arm adjust for proper support in all four presses
		Int'l 172 cm x 106 cm x 206 cm	90 kg	Height adjustable seat and dual handle positions
CT-MEC	Multi-Leg Ext/Curl	US 65" x 42" x 78"	200 lbs	Ankle rollers adjust automatically to different heights
		Int'l 165 cm x 106 cm x 198 cm	90 kg	Lying leg curl position protects the lower back
CT-MLP	Multi-Leg Press	US 81" x 42" x 78"	200 lbs	1" (25mm) ball bearings at every pivot
		Int'l 206 cm x 106 cm x 198 cm	90 kg	Eight seat positions and large non-skid footplate
CT-MFD	Multi-Fly/Delt	US 61" x 45" x 82"	200 lbs	Dual ten position cams for varying ranges of motion
		Int'l 154 cm x 114 cm x 209 cm	90 kg	Five seat height positions and long pivoting arms for a proper fit
CT-MAB	Multi-Ab/Back	US 50" x 39" x 62"	200 lbs	Adjustable seat height and foot brace positions
		Int'l 127 cm x 99 cm x 157 cm	90 kg	Ab/Back pad adjusts for varying ranges of motion
CT-MBT	Multi-Bi/Thi	US 53" x 44" x 62"	150 lbs	Unique pushback exercise works entire triceps
		Int'l 135 cm x 111 cm x 157 cm	68 kg	Ball bearings and ergonomic handles for comfort
CT-MIO	Multi-Inner/Outer	US 61" x 27" x 62"	150 lbs	Rotating thigh pads with padded ankle supports
		Int'l 154 cm x 68 cm x 157 cm	68 kg	Easily adjustable wide range of motion cam
CT-MHP	Multi-Hip	US 43" x 41" x 62"	150 lbs	Unique design gives instant resistance at exercise start
		Int'l 109 cm x 104 cm x 157 cm	68 kg	Adjustable arm accommodates varying heights
CT-CLM	Cable Column	US 46" x 50" x 91"	200 lbs	Cable routing designed for low resistance and long cable pulls
		Int'l 118 cm x 127 cm x 231 cm	90 kg	Eighteen height positions and dual handles
CT-CCO	Cable Crossover	US 159" x 48" x 81"	2x200 lbs	Two fully adjustable cable columns
		Int'l 159 cm x 122 cm x 231 cm	2x90 kg	Chin-up bar and four stability handles
FT1000	Functional Trainer	US 62" x 36" x 88"	2x150 lbs	Standard 2:1 cable pull to weight ratio. Optional 4:1 cable pull kit available
		Int'l 158 cm x 95 cm x 222 cm	2x68 kg	24 exercise heights. Integral step to reach pull-up bar
CT-ILPC	Incline Leg Press/Calf	US 73" x 39" x 78"	200 lbs	2" diameter chromed rails and ball bearing hubbed wheels for smooth operation
		Int'l 185 cm x 99 cm x 198 cm	90 kg	Knurled chromed calf raise bar
CT-MSEC	Seated Leg Ext/Curl	US 52" x 45" x 62"	150 lbs	Self-adjusting ankle pad. Easy to understand labels and placards
		Int'l 132 cm x 115 cm x 157 cm	68 kg	Unique design gives instant resistance at exercise start
freeweight equipment				
5003	Smith Machine	US 78" x 50" x 85"	n/a	Counterbalanced bar with smooth travel on 1" Linear bearings
		Int'l 198 cm x 127 cm x 215 cm		Six weight horns
5005	FID Bench	US 53" x 31" x 49"	n/a	Flat, incline, decline bench with rollers to easily move
		Int'l 135 cm x 79 cm x 125 cm		Seven back pad and four seat pad positions
5001	Ab Bench	US 60" x 24" x 37"	n/a	Bench quickly locks to ten positions
		Int'l 153 cm x 62 cm x 93 cm		18 degrees to 38 degrees incline
5002	Flat Bench	US 53" x 12" x 19"	n/a	Rugged
		Int'l 135 cm x 30 cm x 47 cm		Tripod design for unobstructed foot placement
5070	Hyper Extension Bench	US 49" x 33" x 82"	n/a	45 degree, assist handles
		Int'l 125 cm x 83 cm x 81 cm		Nine height positions
5000	Olympic Bench	US 67" x 70" x 48"	n/a	Two bar rest heights
		Int'l 170 cm x 179 cm x 122 cm		Four weight horns
5004	Dumbbell Rack	US 67" x 24" x 32"	n/a	Holds ten pair hex dumbbells (55-50lb) Wide shelf version available to hold six pair hex dumbbells (55-80lb). Staggered shelves for easy access
		Int'l 170 cm x 62 cm x 81 cm		Inward angled arm pads
VKR	Vertical Knee Raise/Dip	US 28" x 42" x 65"	n/a	Properly angled grips for dip and knee raise
		Int'l 71 cm x 107 cm x 165 cm		Fully welded 2" x 4" side frames. 30 holes for maximum adjustability
5006	Power Rack	US 69" x 67" x 97"	n/a	1 1/4" diameter standard spotter arms. Large 40" x 38" inside work area
		Int'l 175 cm x 170 cm x 246 cm		

INFLIGHT FITNESS WARRANTY: LIFETIME AGAINST DEFECTS, LIFETIME FRAME AND WEIGHT PLATES, ONE YEAR CABLES AND MOVING PARTS
See warranty for details



LIBERATOR

Five Stack Fitness System



STATIONS

- STATION 1** -- Chest Press, Ab Crunch, Overhead Triceps.
- STATION 2** -- Leg Extension, Leg Curl.
- STATION 3** -- Bicep Curl, Low Row.
- STATION 4** -- Lat Pulldown, Shoulder Press.
- STATION 5** -- Cable Cross.

STANDARD FEATURES

- ✓ 1" pillow block bearings on the press arm, 1/4" 4000 pound rated cables and large 4 1/2" and 6" pulleys ensure durability and quiet smooth operation.
- ✓ Five 200 lb. tiered weight stacks.

OPTIONAL FEATURES

- ✓ Steel shrouds powder coated and clear coated for a mar resistant and lustrous finish.
- ✓ Weight stacks can be upgraded in 50 lb. increments up to 300 lbs each.
- ✓ Choice of overall length.

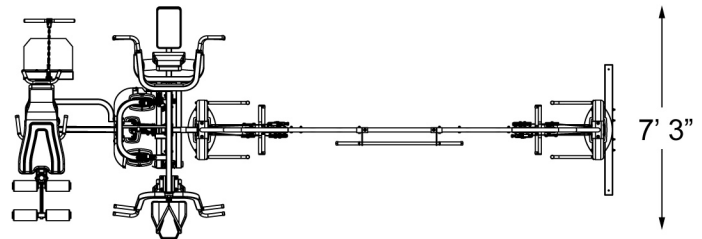

18' 8"

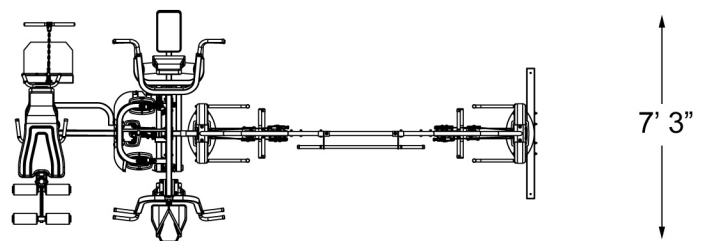

16' 2"

Visit www.inflightfitness.com to see our entire line of exercise equipment.



INFLIGHT FITNESS

VANGUARD

Four Stack Fitness System



3090MFS

218" x 80" x 94"

STATIONS

STATION 1 -- Multi-Press (Shoulder, Incline, Chest, Decline), Lat Pull, Tricep Pushdown.

STATION 2 -- Leg Extension, Leg Curl.

STATION 3 -- Bicep Curl, Low Row.

STATION 4 -- Cable Crossover.

STANDARD FEATURES

- ✓ 1" ball bearing pivots on the press arms and large 4 1/2" and 6" pulleys ensure durability and smooth operation.
- ✓ 17 height adjustments and 2:1 cable pull ratio on the cable crossover.
- ✓ Four 150lb. weight stacks (ten 10lb. plates, ten 5lb. plates).
- ✓ May be assembled as LH or RH to fit room.

OPTIONAL FEATURES

- ✓ Steel shrouds powder coated and clear coated for a mar resistant and lustrous finish.
- ✓ Weight stacks can be upgraded in 50 lb. increments up to 300 lbs.

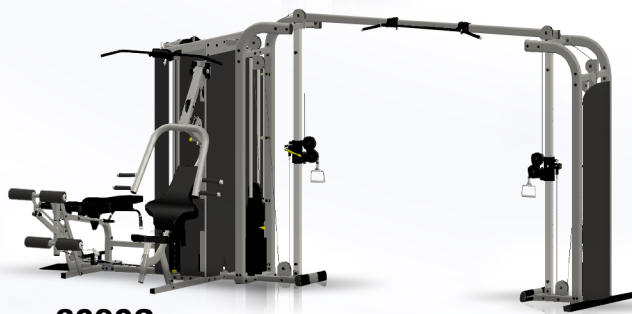

3090S

218" x 80" x 94"



3090CS

188" x 80" x 94"

Visit www.inflightfitness.com to see our entire line of exercise equipment.



VANGUARD

Six Stack Fitness System



3099MFS
295" x 80" x 94"



3099S
295" x 80" x 94"

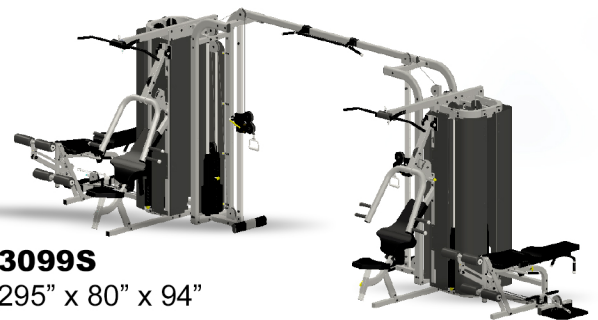

3099CS
265" x 80" x 94"

STATIONS

STATION 1&4 -- Multi-Press (Shoulder, Incline, Chest, Decline), Lat Pull, Tricep Pushdown.

STATION 2&5 -- Leg Extension, Leg Curl.

STATION 3&6 -- Bicep Curl, Low Row.

STATION 7 -- Cable Crossover.

STANDARD FEATURES

- ✓ 1" ball bearing pivots on the press arms and large 4 1/2" and 6" pulleys ensure durability and smooth operation.
- ✓ 17 height adjustments and 2:1 cable pull ratio on the cable crossover.
- ✓ Six 150lb. weight stacks (ten 10lb. plates, ten 5lb. plates).
- ✓ May be assembled as LH or RH to fit room.

OPTIONAL FEATURES

- ✓ Steel shrouds powder coated and clear coated for a mar resistant and lustrous finish.
- ✓ Weight stacks can be upgraded in 50 lb. increments up to 300 lbs.

Visit www.inflightfitness.com to see our entire line of exercise equipment.



INFLIGHT FITNESS

VANGUARD

Dual Stack Gym



STANDARD FEATURES

- ✓ 1" pillow block bearings on the press arm, 1/4" 4000 pound rated cables and large 4 1/2" and 6" pulleys ensure durability and quiet smooth operation.
- ✓ Two 150lb. weight stacks (ten 10lb. plates, ten 5lb. plates).
- ✓ Vanguard assembles in LH and RH configurations to offer the best exercise experience for your fitness room.

OPTIONAL FEATURES

- ✓ Steel shrouds powder coated and clear coated for a mar resistant and lustrous finish.
- ✓ Weight stacks can be upgraded in 50 lb. increments up to 300 lbs. each.
- ✓ Leg press, calf raise and/or cable column attachment.

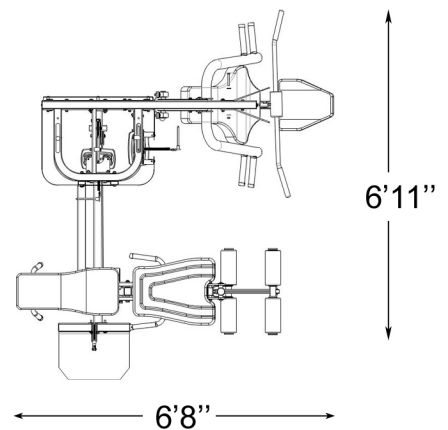

Visit www.inflightfitness.com to see our entire line of exercise equipment.

Lifetime limited warranty on frame, welds and weights; one year on cables and moving parts. See warranty for details.

INSPIRE™

A Low Impact, Total Body Workout



Patent Pending

01-17

Health in Motion, LLC Inspire Fitness & Sunset Swings - 255 Airport Cir Suite 101 Corona , CA 92880

Phone (877) 738-1729
Fax (714) 738-1728

By Inspire Fitness
www.inspirefitness.com

CS2.5



Scan for more information

Dimensions
35" W x 60" L x 50" H

Max User Weight
350lb

Warranty (Residential)
Lifetime frame, 3 years parts, 1 year labor

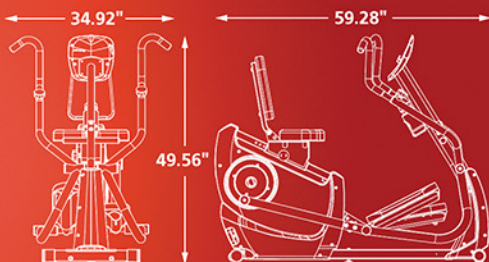

CS3



Scan for more information

Dimensions
35" W x 60" L x 54" H

Max User Weight
350lb

Warranty (Residential)
Lifetime Frame, 5 years parts, 1 year labor

Warranty (Light Commercial)
10 years frame, 1 year parts, 1 year labor

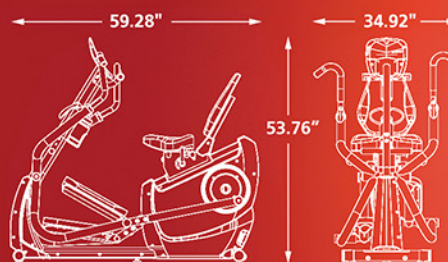



Scan for more information

	CS2.5	CS3	CS4
Blue Backlit Screen	✗	✓	✓
Computer Preset Programs	✓	✓	✓
Safety Lock	✓	✓	✓
Quick Release Handles	✗	✓	✓
Adjustable Back Pad Tilt	✓	✓	✓
Swivel Seat	✗	✗	✓
Motorized Seat Height Adjustment	✗	✗	✓
Contact Heart Rate Grips	✗	✓	✓
Telemetric Heart Rate Receiver	✗	✓ <i>Polar Chest Strap included</i>	✓ <i>Polar Chest Strap included</i>

Dimensions
36" W x 72" L x 55" H

Max User Weight
350lb

Warranty (Residential)
Lifetime Frame, 5 years parts, 1 year labor

Warranty (Light Commercial)
10 years frame, 2 years parts, 1 year labor

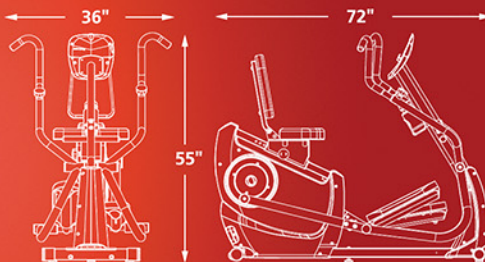

Inspire/Health In Motion LLC. reserves the right to alter product specifications at any time.
These products covered by one or more of the following US Patents and others pending:
5,330,405; 5,944,641; 5,961,427; 7,645,217; 7,722,513; 7,837,600; 7,905,818; 8,096,929; 8,870,718



Product	Model #	MAP Pricing
Multi-Gyms		
BL1 Body Lift	BL1	\$ 1,399.00
M1 Multi Gym	M102	\$ 1,799.00
M2 Multi Gym	M202	\$ 2,499.00
M3 Multi Gym	M302	\$ 3,499.00
M5 Multi Gym	M5.2	\$ 4,499.00
Leg Press Option	LP3	\$ 1,099.00
Functional Trainers		
FT1 Functional Trainer	FT1	\$ 2,499.00
FT1 Functional Trainer (w/ FT1 Bench)	FT1, FIDB	\$ 2,799.00
FT2 Functional Trainer	FT2	\$ 3,999.00
FT2 Functional Trainer (w/ SCS Bench, Leg Att., and Leg Kit)	FT2, SCS-WB2, SCS-LE, FT2-LK	\$ 4,499.00
Cardio		
CB1 Air Bike	CB1	\$ 599.00
CS2.5 Cardio Strider	CS2.5	\$ 1,599.00
CS3 Cardio Strider	CS3	\$ 2,199.00
CS4 Cardio Strider	CS4	\$ 3,799.00
IC1 Indoor Cycle	IC1.2	\$ 999.00
IC2 Indoor Cycle	IC2.2	\$ 1,299.00
IC2 Indoor Cycle (w/ Display)	IC2.2, IC2D	\$ 1,399.00
CR2.1 Cross Rower	CR2.1	\$ 1,999.00
Free Weight		
Power Rack	SCS-002	\$ 1,099.00
SCS Smith Option	SCS-102	\$ 599.00
SCS Functional (w/ Weights)	SCS-202	\$ 2,199.00
Power Rack/Functional	SCS-0, SCS-2, SCS-WB, SCS-LE, SCS-PC, Shroud	\$ 3,999.00
Full SCS System	SCS-0, SCS-1, SCS-2, SCS-WB, SCS-LE, SCS-PC, Shroud	\$ 4,499.00
VKR Vertical Knee Raise	VKR1.2	\$ 799.00
Mini-Crunch Bench (Optional Att. for VKR)	MCB1	\$ 199.00
Ab Bench	ACB1	\$ 699.00
45/90 Hyperextension Bench	HYP1	\$ 449.00
Squat Rack (w/ Safeties)	SQR1.2	\$ 699.00
3-Tier Dumbbell Rack	DBRH	\$ 269.00
Vertical Dumbbell Rack	VDB8	\$ 269.00
Bumper Plate Tree	PTV2	\$ 199.00
FLB2 Folding Bench	FLB2	\$ 209.00
FT1 Bench	FIDB	\$ 329.00
SCS Bench	SCS-WB2	\$ 399.00
Commercial		
Commercial Strength Chest/Shoulder	DMCS1	\$ 2,799.00
Commercial Lat Row	DMLR1	\$ 2,499.00
Commercial Strength Bicep/Tricep	DMBT1	\$ 2,699.00
Commercial Leg Press/Calf	DMLC1	\$ 2,599.00
Commercial Leg Extension/Curl	DMEC1	\$ 2,699.00
Accessories and Options		
Accessory Rack	RAO1	\$ 69.99
Ab Bar	ABB1	\$ 99.99
Aluminum Lat Bar	LBA3	\$ 99.99
Aluminum EZ Curl Bar	CBA1	\$ 89.99
Leg Extension (Requires FT1 or SCS Bench)	SCS-LE	\$ 139.00
Preacher Curl (Requires FT1 or SCS Bench)	SCS-PC	\$ 99.00
FT1 Accessory Kit	FT1U	\$ 149.99

FT2 Leg Ext. Conversion Kit	FT2-LK	\$ 49.99
Heavy Stack Add-On (50lbs)(For all gyms)	W5.1	\$ 129.99
5lb. Add-On Weight	ADW5	\$ 29.99
Polar T34 Heart Rate Strap (CR2.1)	HRTS	\$ 39.99
IC2 Indoor Cycle Console	IC2D	\$ 100.00

Pads and Shrouds

Charcoal Pad	OPCO	\$ 139.99
Tan Pad	OPTO	\$ 139.99
Burgundy Pad	OPB0	\$ 139.99
Navy Pad	OPN0	\$ 139.99
Charcoal Shroud	SHC2	\$ 99.99
Tan Shroud	SHT2	\$ 99.99
Burgundy Shroud	SHB2	\$ 99.99
Navy Shroud	SHN2	\$ 99.99

INSPIRE™

Check out our workouts on the web!



Scan for more
information

Shown with Optional Bench

FT-1

By Health In Motion LLC.
Phone (877) 738-1729 · Fax (714) 738-1728
www.inspirefitness.net

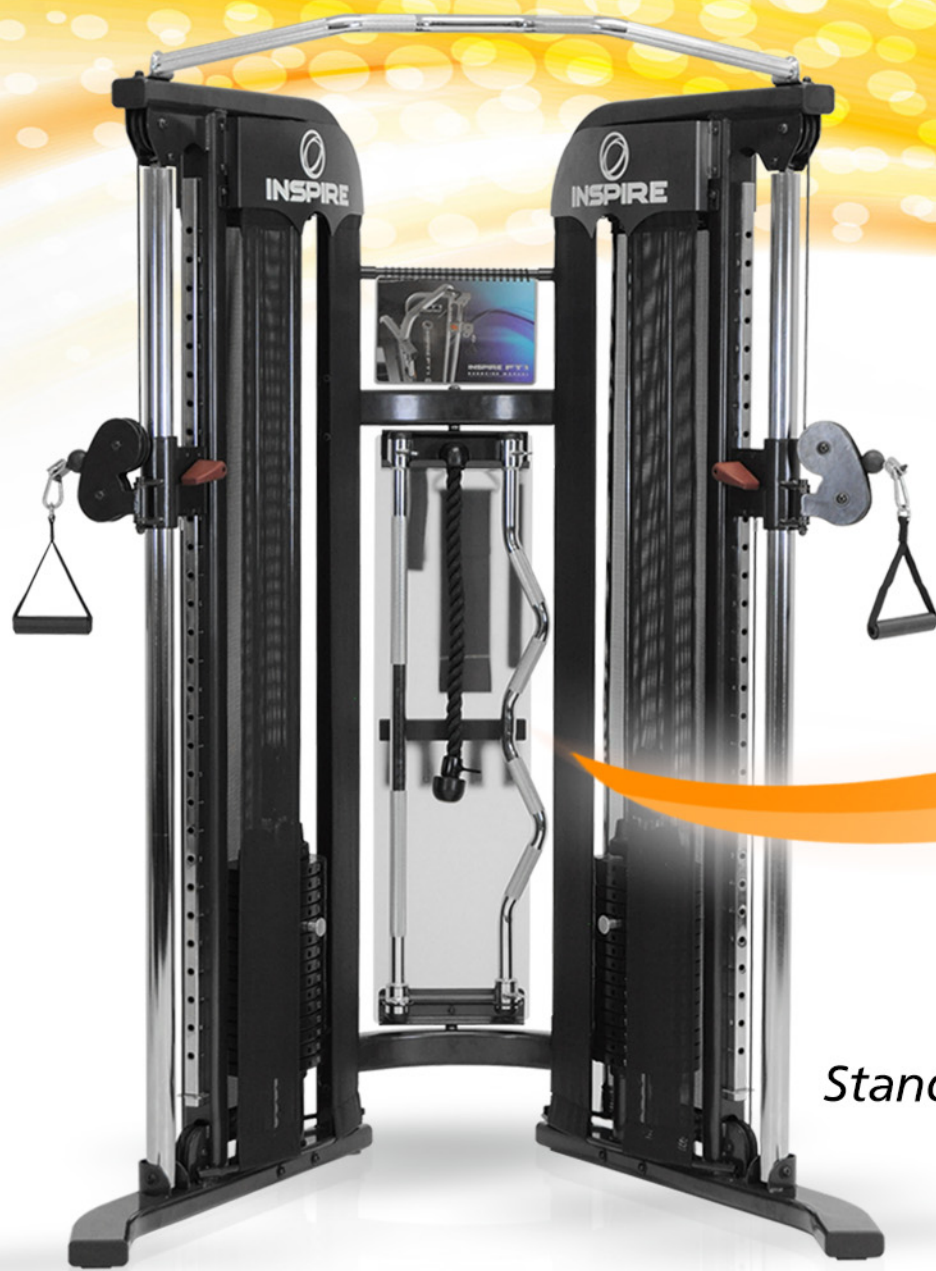

Standard FT1



*Rotating
Accessory Rack*

FT1 Product Specifications

Frame: Heavy-duty rectangular and round tubular steel.

Powder Coated Finish: The Electrostatic Powder Coat offers a durable, maintenance free finish.

Instructional Flip Chart: Offers color photos with over 40 different exercises right at your finger tips.

User-friendly adjustments: The quick, one-handed adjustable high/low pulley system adjusts to more than thirty height positions for all of your exercise needs.

Dual Independent Weight Stacks: The dual weight stacks allow you to work each side of the body independently for a more balanced workout.

Split Resistance: .5 resistance ratios provide a smooth, continuous feel and a longer range of motion for more versatility in your exercise movements.

Weight Stacks: 2 - 165 lb Commercial Weight Stacks with Solid Guide Rods and Center Drilled Weight Plates.

Rotating Accessory Holder: Includes the Multi-Functional Belt, Easy Curl Bar, Straight Bar, Ankle Cuff, Swing Handle, Tricep Rope, 2 – Single Handles, and 2 – 5 lb add-on weights.

Options Available: FID Bench, 50lbs Weight Stack add-on, and Abdominal Bar.

Warranty: Inspire (Health In Motion LLC.) Multi-Gyms have a (Residential) Lifetime Limited Warranty and a 10 Year Light-Commercial Warranty. Visit your local dealer for

Dimensions:

FT1 Footprint: Depth 47" x Width 54" x Height 81.5"

FT1 Footprint w / Optional Bench: Depth 83" x Width 54" x Height 81.5"

Inspire/Health In Motion LLC. reserves the right to alter product specifications at any time.

This product covered by one or more of the following US Patents and others pending:
5,330,405; 5,961,427; 5,944,641; 7,905,818; 7,837,600; 7,645,217; 8,096,929; 7,722,513.

INSPIRE™



**CHECK OUT
OUR WORKOUTS
ON THE WEB!**



Scan for more
information

Shown with optional bench

- **Unique design integrates Olympic bar and weight stacks, eliminating the need for Olympic weight plates.**
- **Dual pulley system adjusts to 32 positions for unlimited functional training capability.**
- **Pull-up bar is adjustable in height to accommodate low ceiling height.**
- **Optional leg extension/leg curl attachment conveniently hooks up to weight stacks for a smooth, commercial feel.**
- **Innovative weight multiplier feature doubles maximum resistance to accommodate heavy lifters.**

FT2

By Health In Motion LLC.
Phone (714) 738-1729 • Fax (714) 738-1728
www.inspirefitness.net

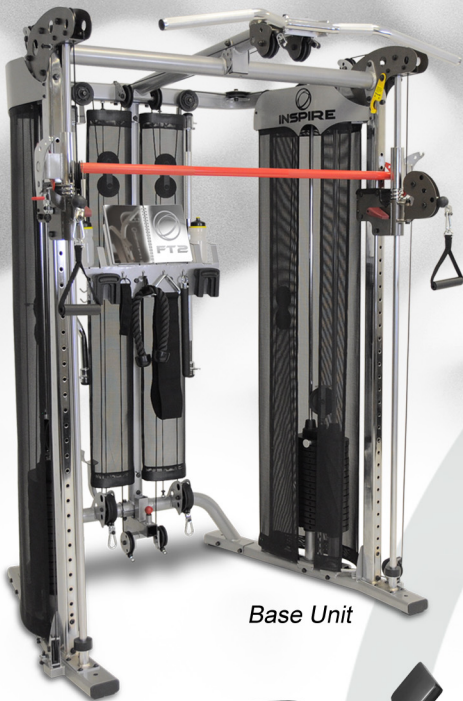

Base Unit

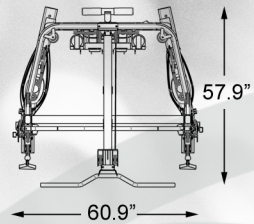

Minimum Height: 83"
Maximum Height: 88"

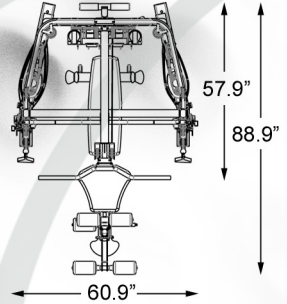

Optional FID Bench



Optional FID Bench
& Optional Preacher Curl



Optional FID Bench
& Optional Leg Developer

FT2 Product Specifications

Frame: Heavy-duty rectangular and round tubular steel.

Powder Coated Finish: The Electrostatic Powder Coat offers a durable, maintenance free finish.

Bearing System: Precision steel ball bearing system provides a smooth, maintenance free action.

Pulleys: Fiberglass reinforced nylon.

Dual Independent Weight Stacks: The dual weight stacks allow you to work each side of the body independently for a more balanced workout.

Weight Stacks: Two 150lb. commercial weight stacks with center drilled holes and magnetic weight pin for safety.

Accessories: Tricep rope, pair of D handles, straight bar, EZ curl bar, ankle cuff, two water bottles, multi-function belt, swing handle, 2 - 5lb. add-on weights, exercise booklet.

Options Available: 200lb. weight stack upgrade. FID bench, leg developer attachment, preacher curl attachment, abdominal bar.

Warranty: *Residential:* Limited Lifetime on frame and all parts. *Light Commercial:* Limited 10yr. on frame and all parts. Supervised settings only.

This product covered by one or more of the following US Patents and others pending: 5,330,405; 5,961,427; 5,944,641; 7,905,818; 7,837,600; 7,645,217; 8,096,929; 7,722,513; 7,645,217.

Inspire/Health In Motion LLC. reserves the right to alter product specifications at any time.